

# Naclean Mine-Mate

## EC-3 Emulsion Charger

A cost effective and highly productive solution for delivering high explosive energy to blast holes, the EC-3 Emulsion Charger is specifically designed for the exacting standards necessary for the transport and pumping of bulk emulsion in the underground work environment.

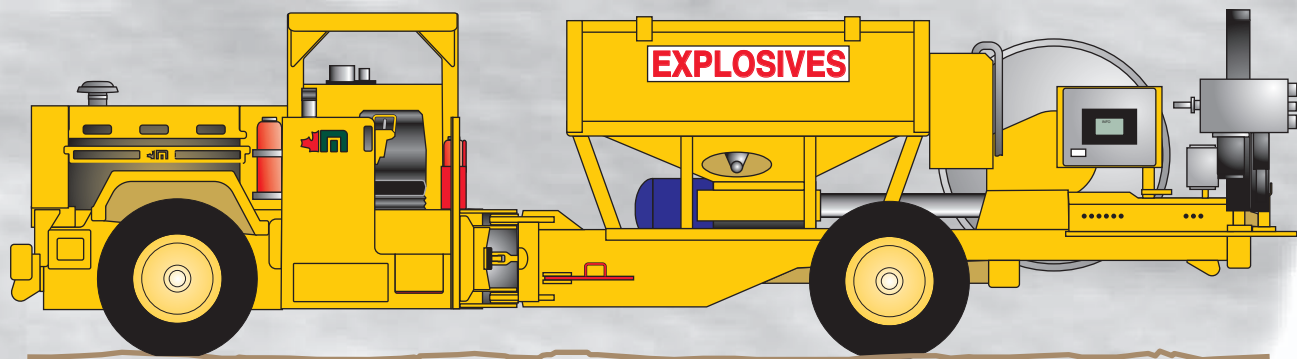

### FEATURES:

- Self-contained charging system with 4100 kg emulsion payload
- Ample separate storage capacity for caps and blasting supplies
- Stainless steel pumping components
- PLC with “touch screen” controls
- Safety interlock systems
- Heavy duty frame construction
- Adaptable to explosives manufacturers' specifications
- High-powered, electronically controlled Caterpillar™ engine
- Reliable, proven power train components
- Four wheel drive carrier
- Cab location options (forward/midships)

### BENEFITS:

- Wide coverage from single set-up
- Pre-programmed, variable charging densities and pump rates
- Improvement in primary blast efficiency controls fragmentation and maintains stope integrity; reduction in secondary breaking requirements
- Productivity improvements, especially in up-hole loading
- Material handling advantages
- Auxilliary pumping system enables in-stope re-supply of emulsion product
- Reduced environmental impact from spillage and contamination
- Reduction in overall mining costs through drill pattern expansion, improved breakage, reduced manpower requirements and increased LHD productivity
- Long life power train using proven Caterpillar™ components
- Ease of maintenance with electronic engine diagnostics, accessible fuel filling and grease points
- Clean burning, fuel-efficient engine minimizes harmful emissions
- Superior traction due to four wheel drive and powershift transmission

### APPLICATIONS:

- Blasthole charging of upholes and downholes
- Bulk emulsion transport
- Accurate explosive charging for precision blasting

# TECHNICAL SPECIFICATIONS

## OPERATING SYSTEM - EC-3 EMULSION CHARGER

### CARRIER - MACLEAN SERIES 977

- Caterpillar™ 3056E diesel engine, 6-cylinder, liquid cooled, 111 kW, EPA Tier II certified, MSHA approved
- Caterpillar™ 928-G Series 3-speed powershift transmission
- Caterpillar™ 938-G Series axles, 16,000 kg capacity, 10° oscillation (front axle)
  - › Independent front/rear hydraulically operated service brakes
  - › Automatic brake application (ABA) with manual re-set
  - › Spring applied, hydraulically released wet disc driveline brake
  - › Braking system to CAN/CSA-M424-3-M90 Standard
- Steering angle 40°; centre articulated; dual hydraulic cylinders; orbital or stick steer control
- Tires: 12:00 x 20 mine-rated; pneumatic or solid
- 24-volt electrical system; 95-amp alternator
- Closed centre hydraulic steering and brake circuit; system pressure 200 bar
- Exhaust (heat shielded); catalytic purifier/muffler
- Air cleaner
- 95-litre fuel tank
- Midships (side-mounted) driver's compartment (open or enclosed cab)
- Speed range (level):
  - 1st gear . . . . . 6 km/h
  - 2nd gear . . . . . 10 km/h
  - 3rd gear . . . . . 21 km/h
  - 15% ramp (empty) . . . . . 7.5 km/h
- Maximum Grade . . . . . 20%

### OVERALL DIMENSIONS

- Length: . . . . . 8760 mm
- Width: . . . . . 2290 mm
- Trimming Height: . . . . . 2440 mm
- Turning radius: Inner . . . . . 6000 mm  
Outer . . . . . 8635 mm
- Tare weight: . . . . . 16,900 kg
- Gross weight: . . . . . 21,000 kg

### PUMPING SYSTEM

#### Components:

- Hiab 032 crane; range 7.12 metres
- Stainless steel hose pusher
- Hose feeder with 60 metres x 38mm non-static loading hose
- Aluminum hopper 3000 litre (4100 kg) capacity
- Water tank 270 litre
- Emulsion feeder pump
- Shear valve
- Gassing unit
- Hydraulic controls (positioning mechanisms)
- PLC and “touch screen” controls (pumping system)
- Auxilliary hard wired 24-volt remote pendant
- Emulsion transfer pump
- Maximum hole depth 60 metres
- Single hopper charge loads 275 metres of 114 mm diameter holes
- Pumping rates of up to 70 kg/minute
- Water pump and compressor provide hose lubrication and system cleaning capability

### MISCELLANEOUS EQUIPMENT

- Fire suppression system
- Portable fire extinguisher
- “Explosives” signs
- Articulation lock bar
- Strobe light
- Tow lugs

### AVAILABLE OPTIONS\*

- Certified ROPS (open canopy)
- Telescopic FOPS
- Enclosed cab, heated/air conditioned (ROPS certified)
- Automatic fire detection system
- Auto greasing kit
- Air suspension seat (driver)
- 44.5 x 16.5 pneumatic aircraft tires
- Caterpillar™ 3126B engine, 135 kW
- Engine brake
- “Wiggins” fast fuelling system
- Wheel chocks (set of two)



is a registered trade-mark of MacLean Engineering & Marketing Co. Ltd.

\* All options must be pre-approved by MacLean Engineering & Marketing Co. Ltd.



# EC-3 Emulsion Charger

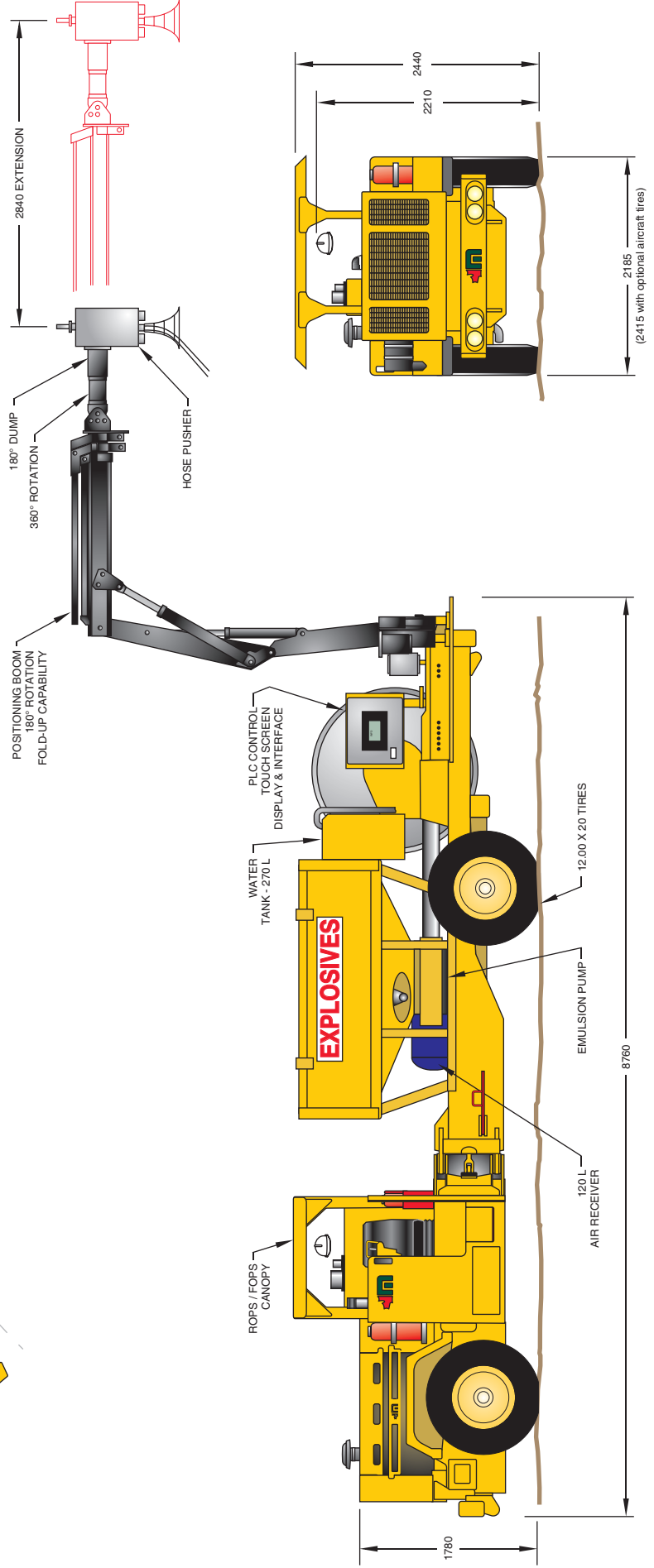
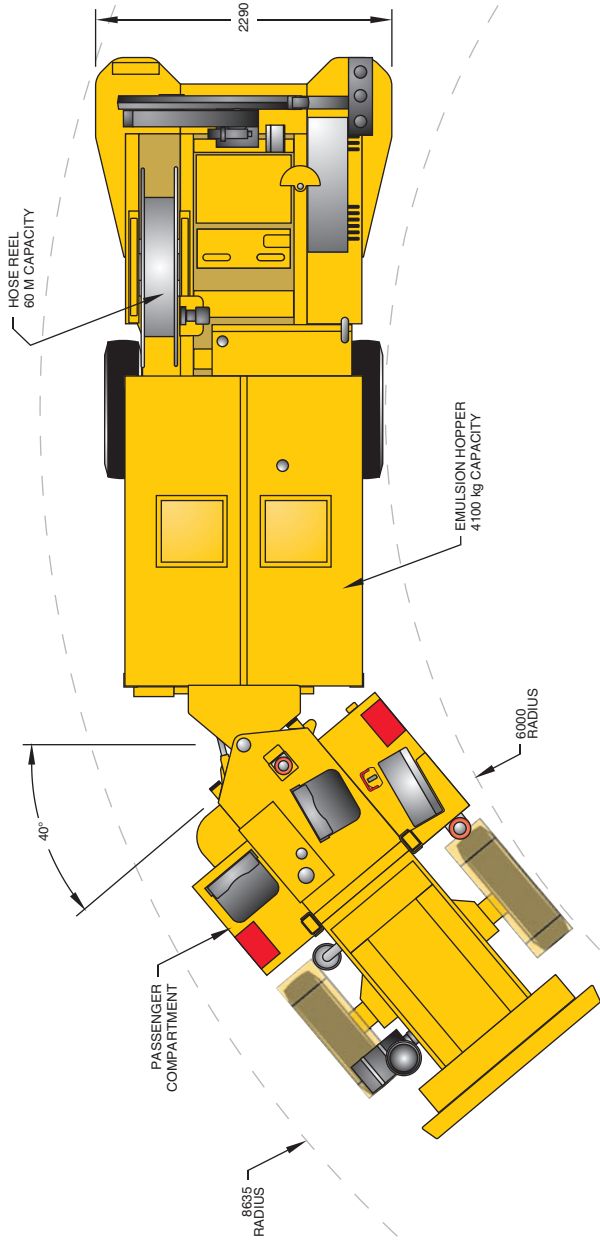

# NOTES



## maclean engineering & marketing co. limited

*Designed and manufactured by*

**Head Office** 



**Service Centre** 

*Address:* 1000 Raglan Street  
Collingwood, Ontario, Canada L9Y 3Z1

*Customer Service:* 1-866-856-3626 (Toll Free)  
1-705-445-5707 (International)

*Fax Number:* 1-705-445-3214

*e-mail:* [sales@macleanengineering.com](mailto:sales@macleanengineering.com)

*Address:* 1154 Webbwood Drive  
Sudbury, Ontario, Canada P3C 3B7

*Customer Service:* 1-705-670-8014  
1-705-670-8395

*Fax Number:* 1-705-670-8176

*e-mail:* [service@macleanengineering.com](mailto:service@macleanengineering.com)

[www.macleanengineering.com](http://www.macleanengineering.com)